

CCS Technical Documentation

RH-17 Series Transceivers

Disassembly

ESD Protection



Remove the six screws using a nonconductive screwdriver.

Remove the battery cover (B-cover)

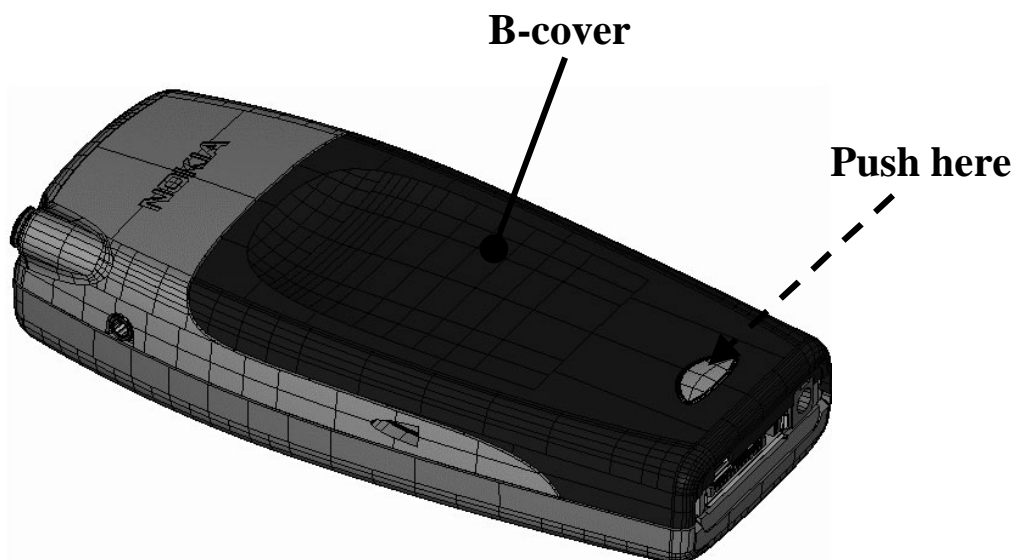

- 1 Turn the phone off.
- 2 Remove the battery cover (B-cover) by pushing down on the release button.
- 3 Remove battery.

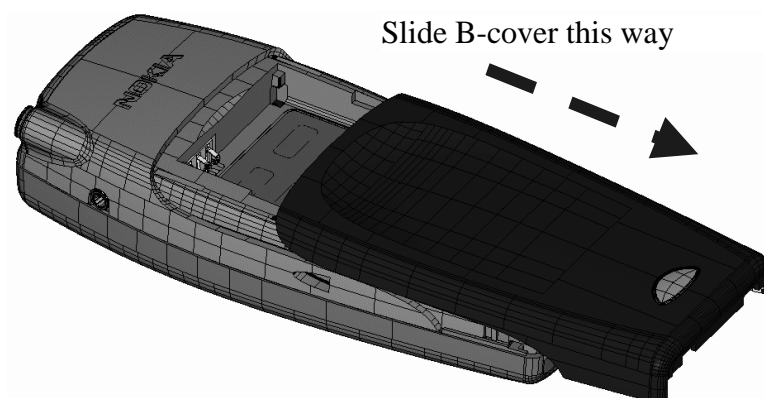

Remove A-cover

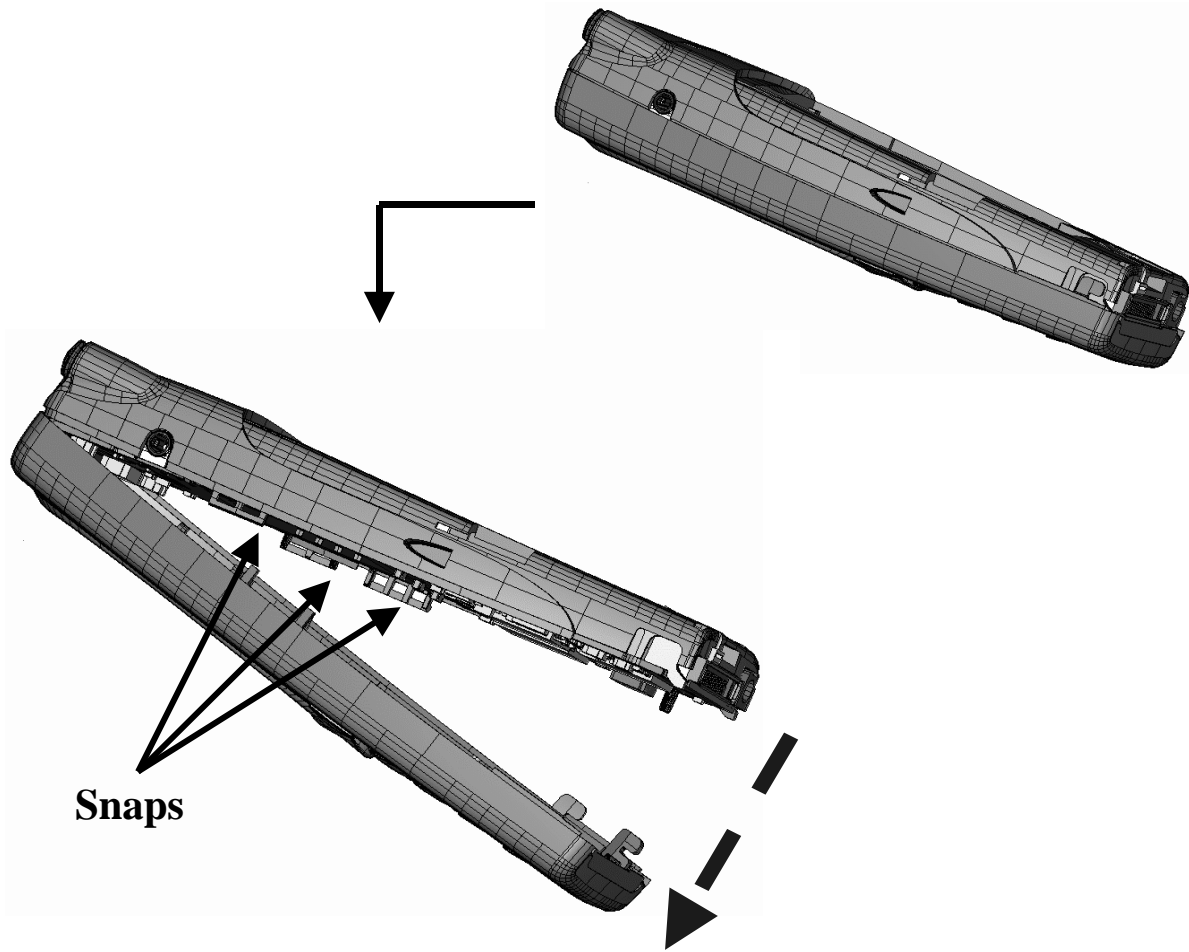

Remove screws using a nonconductive screwdriver

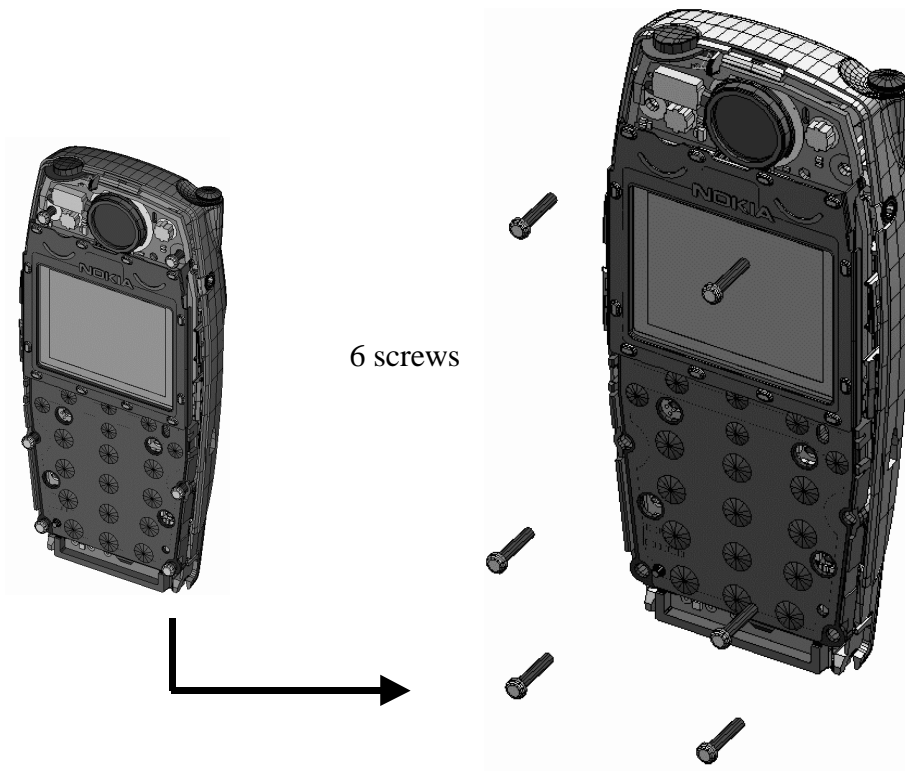

Remove LCD Assembly

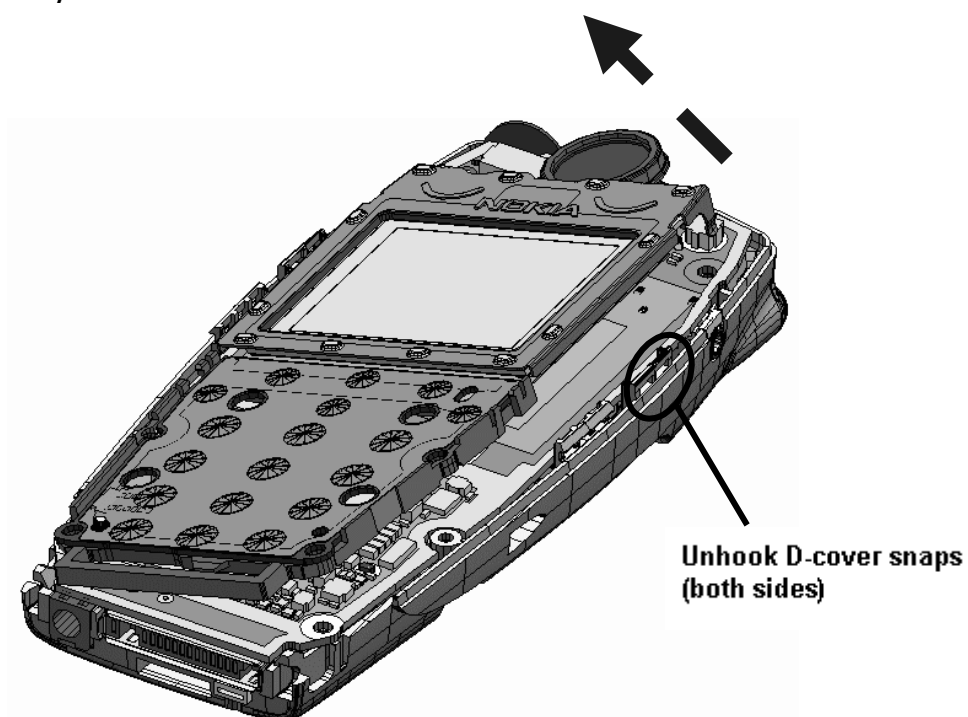

Separate PWB from D-cover Assembly

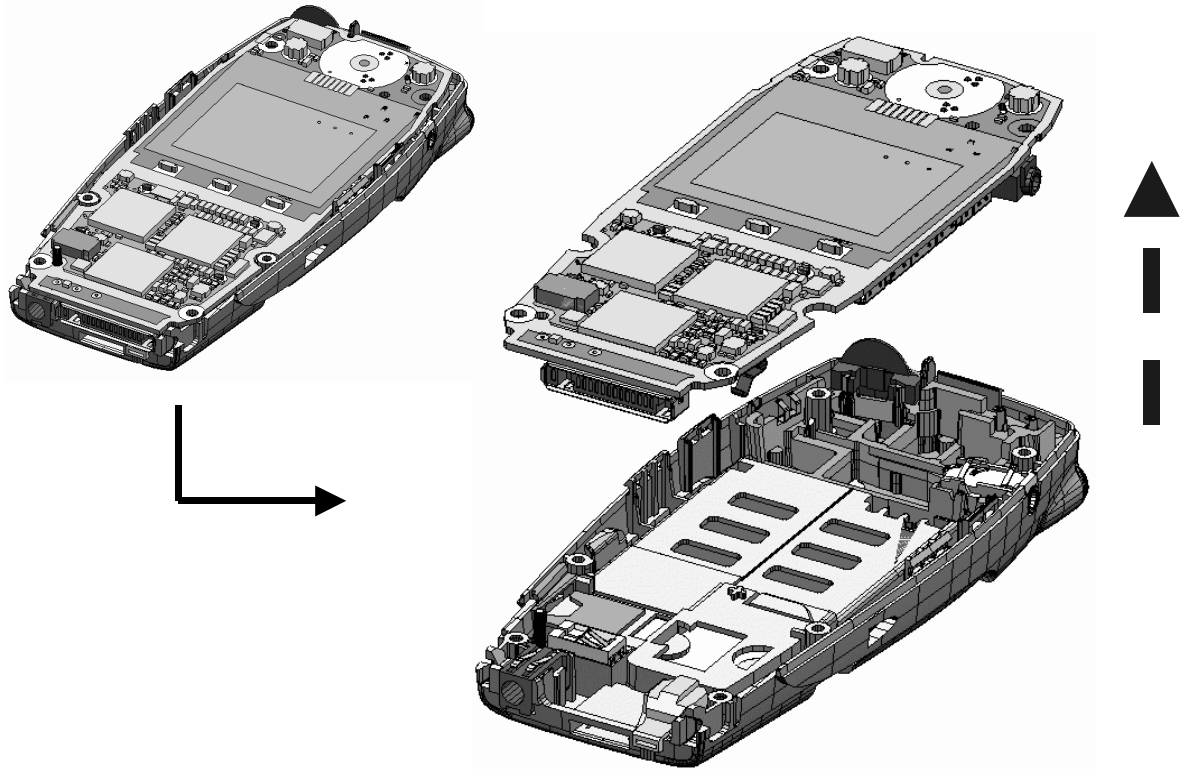

Power Key Removal

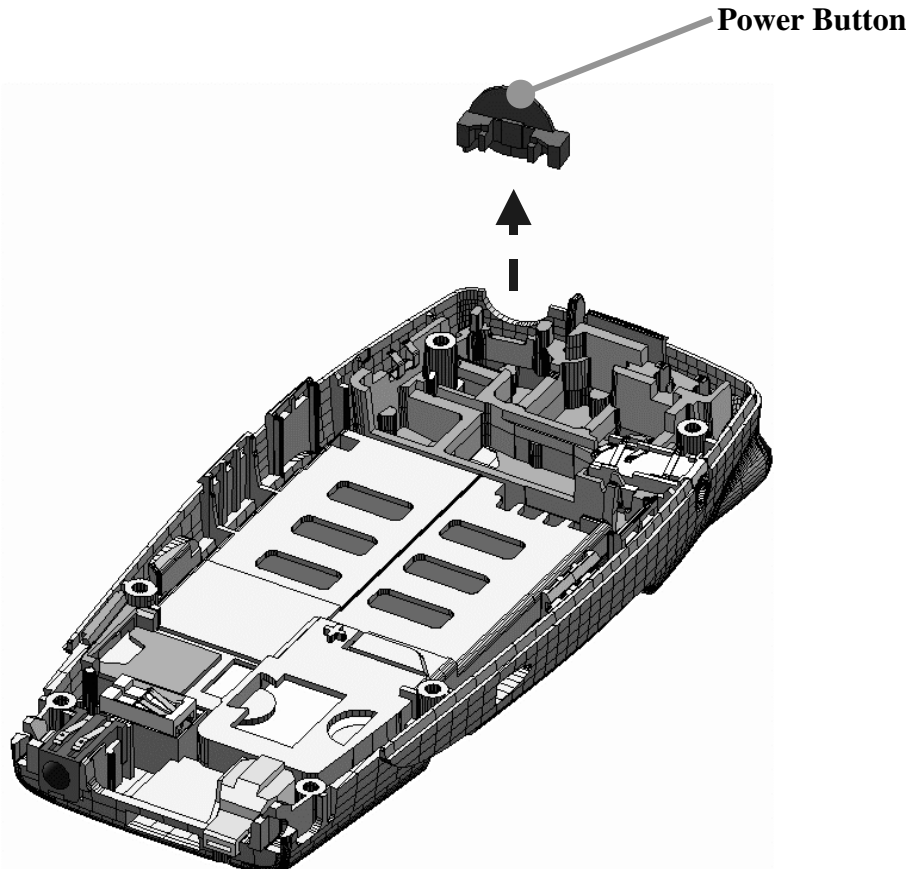

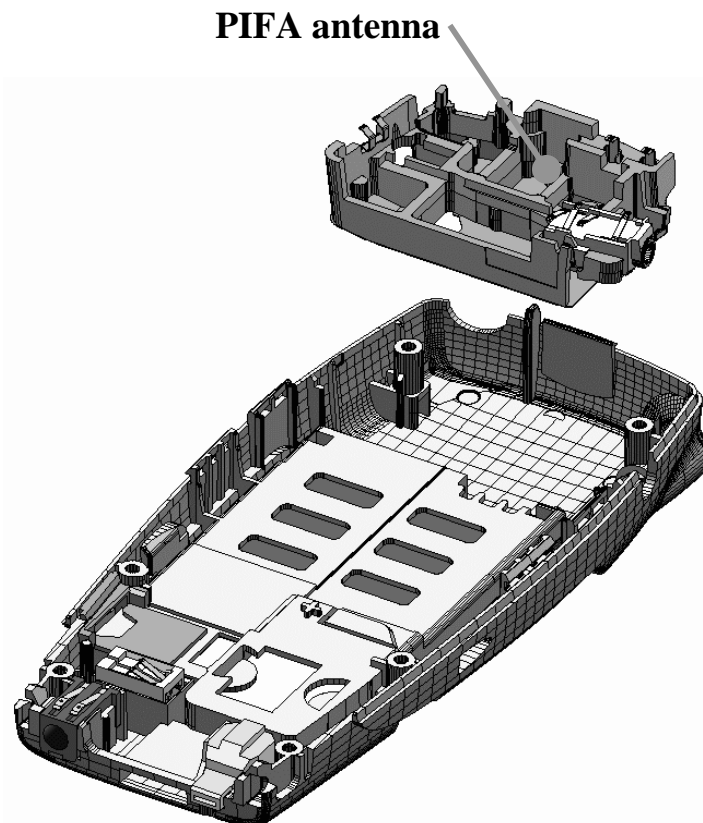
PIFA Antenna Removal**Other Item Removal**

- Headset jack (in PIFA antenna)
- Whip assembly
- DC jack
- Microphone
- Buzzer gasket
- Vibra motor

